

# Cost effective overload protection

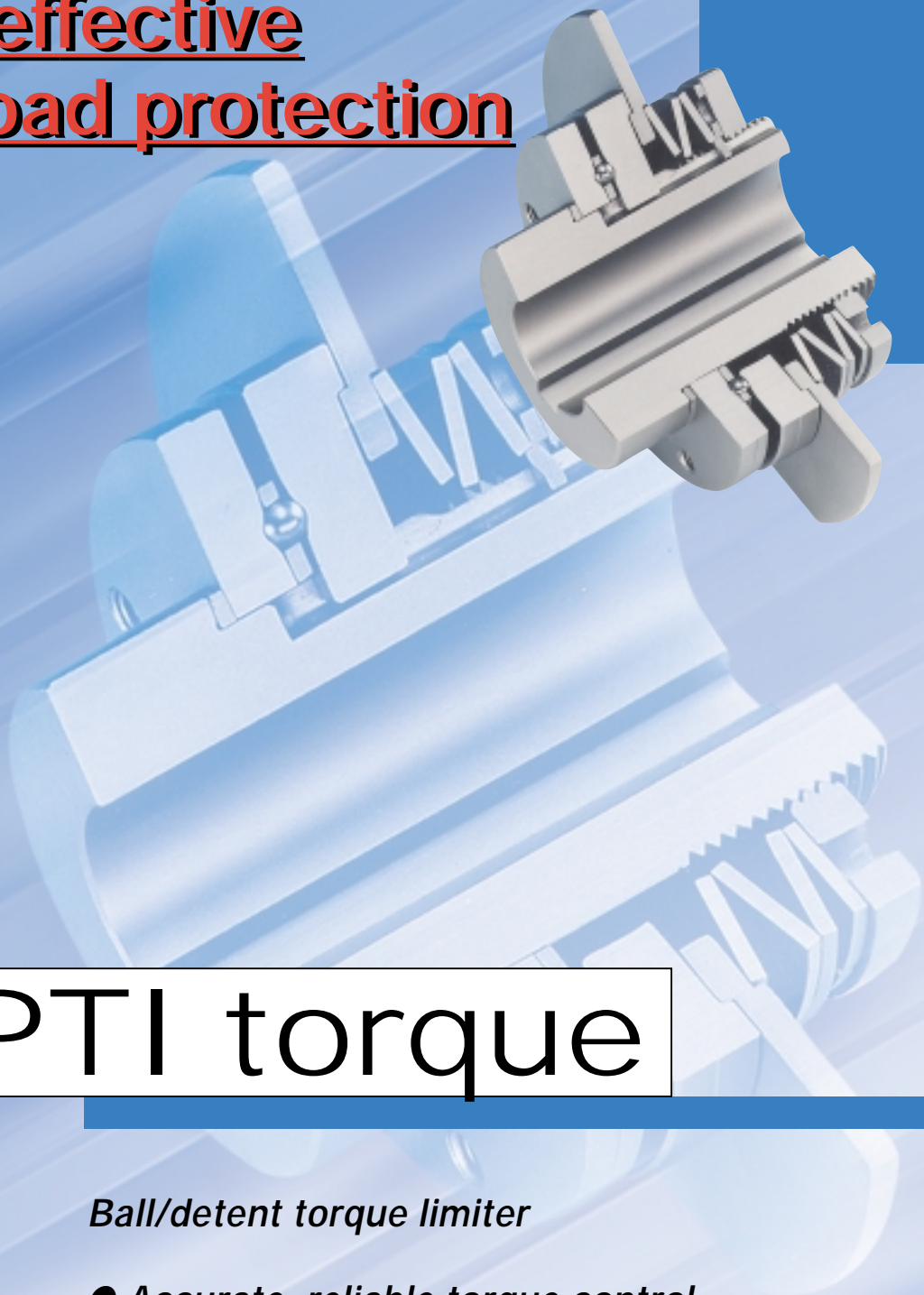

## OPTI torque

### *Ball/detent torque limiter*

- *Accurate, reliable torque control*
- *Wide torque range*
- *Unique system for setting torque*

[www.mayr.de](http://www.mayr.de)

K.460.V06.GB

**mayr**<sup>®</sup>  
power  
transmission

## Why use a torque limiter ?

### The concept:

A torque limiter is a mechanical device that disengages when the transmitted torque exceeds a pre-set value, i.e. when an overload occurs.

People, products, drives, equipment and machines can be protected against the damage caused by overloads, and the costly repairs and unnecessary downtime which can result.

Compared to an overcurrent relay, or other electrical overload devices a torque limiter not only provides a signal in the event of an overload, but instantaneously disengages, isolating the inertia energy of the drive system.

**OPTI torque increases productivity by eliminating expensive machine downtime.**

## Why use OPTI torque ?

### Only OPTI torque offers all the following advantages

- \* OPTI torque assures precise torque control. Even in extreme conditions, repetitive accuracies of +/-5% are achieved.
- \* The OPTI torque system of differing spring weights and configurations results in wide torque ranges for all size units. Low torque applications with large shaft diameters are possible.
- \* OPTI torque's small size yields low mass moments of inertia.
- \* OPTI torque offers a unique system for setting the overload torque, making adjustment both easy and accurate.
- \* OPTI torque features a positive locking arrangement, preventing torque setting changes during operation.
- \* OPTI torque's large diameter limit switch plate allows the use of commercially available, inexpensive limit switch (see page 11). Proximity sensors can be used without limit switch plate installed.

## Engineering Assistance

Please let us know what your specific requirements are and we will be happy to work out, without any obligation, a detailed recommendation. Since our engineers cannot be aware of all applications and control all factors that may affect the function of our products, our warranty applies only to products manufactured by Mayr.

In accordance with our established policy to constantly improve our products, the specifications contained herein are subject to change without notice.

### The practical solution:

Many years of experience developing, improving and manufacturing torque limiting clutches enable us to now offer the ideal mechanical torque limiter for virtually every application. The latest production techniques and quality control systems guarantee consistently high quality products that are economically priced.

### Basic function of OPTI torque:

OPTI torque is a "ball/roller detent torque limiting clutch", transmitting torque via balls and detents (multiple position reset) or rollers are held in their respective detents through the pressure generated by disc springs. When an overload occurs, exceeding the pre-set torque, the balls or rollers ride out of their detents, disengaging the clutch.

The balls or rollers riding out of their detents produce the axial stroke of the limit switch plate, which is used to actuate a mechanical limit switch to shut down the drive. Alternatively, the OPTI torque can be used without a limit switch plate and a proximity switch sensing the axial movement of the control element.

The limiting torque for an overload is set by adjusting the spring pressure on the balls or rollers. This is done by means of an adjusting nut, which is positively locked once the torque has been set. As OPTI torque utilizes rolling disengagement, torque changes due to frictional wear, as in friction type torque limiters, are eliminated. Consistent and repeatable torque settings, unaffected by outside influences such as temperature, humidity or lubrication are the result.

### Options and special designs:

Double "C" face or IEC-flange torque limiter.  
For installation between motor and gear box.

Design for small drive elements.

Covered and sealed units for dusty environments or severe conditions, such as high pressure wash down.

Optional finishes  
OPTI torque standard finish is zinc phosphating.  
Alternative finishes, such as nickel plating, etc., are available upon request.

## OPTI torque

### OPTI torque are available in two basic types:

#### OPTI torque multiple position clutch - for immediate re-engagement

The 24 balls in the OPTI torque multiple position clutch ratchet from one set of detents to the next during an overload. The multiple position OPTI torque therefore immediately and automatically re-engages, as soon as the overload has been cleared. Residual torque transmitted during an overload is substantially lower than the pre-set torque.

#### OPTI torque single position clutch - for timing and sequencing

By utilizing 6 unequally spaced rollers, the OPTI torque single position clutch automatically re-engages after one full revolution, once the overload has been cleared. As re-engagement is at the exact position of disengagement, timing and/or sequencing within the machine is maintained. Residual torque transmitted in disengaged position is substantially lower than the pre-set torque.

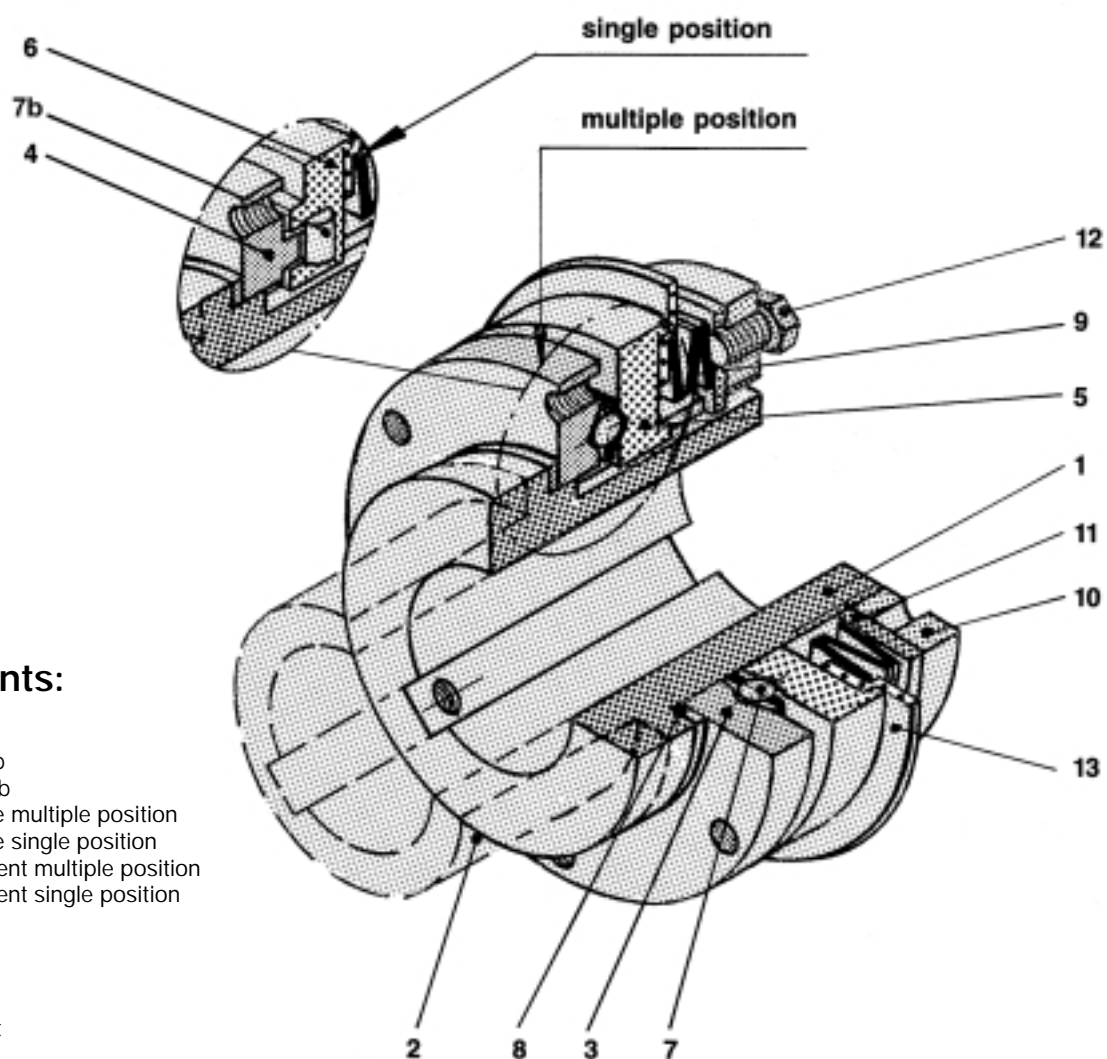

#### Components:

- 1 standard hub
- 2 extended hub
- 3 output flange multiple position
- 4 output flange single position
- 5 control element multiple position
- 6 control element single position
- 7a ball cage
- 7b roller
- 8 axial bearing
- 9 spring
- 10 adjusting nut
- 11 lock washer
- 12 locking screw
- 13 limit switch plate

## Selection Procedure:

OPTI torque's adaptability makes selection easy.

Two basic parameters to be considered:

\* **Torque:** It is essential to determine the torque at the point where OPTI torque will be mounted. The torque should be based on allowable torque for the drive components. Alternatively torque can be calculated from the motor horsepower and operating speed.  
**Remember to consider peak torques due to start-up or other operating conditions that should not lead to disengagement of clutch.**

\* **Shaft diameter:** The overlaps in torque ranges from one size OPTI torque to the next allow different size units to be utilized for the same torque requirement. The determining factor then becomes shaft diameter.

## Location of OPTI torque:

The most effective location for OPTI torque is as close as possible to the potential trouble spot or the drive component which must be protected. Keep in mind the more inertia that is disengaged, results in less energy that can cause damage.

The figures below show the recommended locations for OPTI torque in two typical drive arrangements. Alternate locations A, B and C provide less effective protection, especially when large speed reductions occur beyond the OPTI torque.

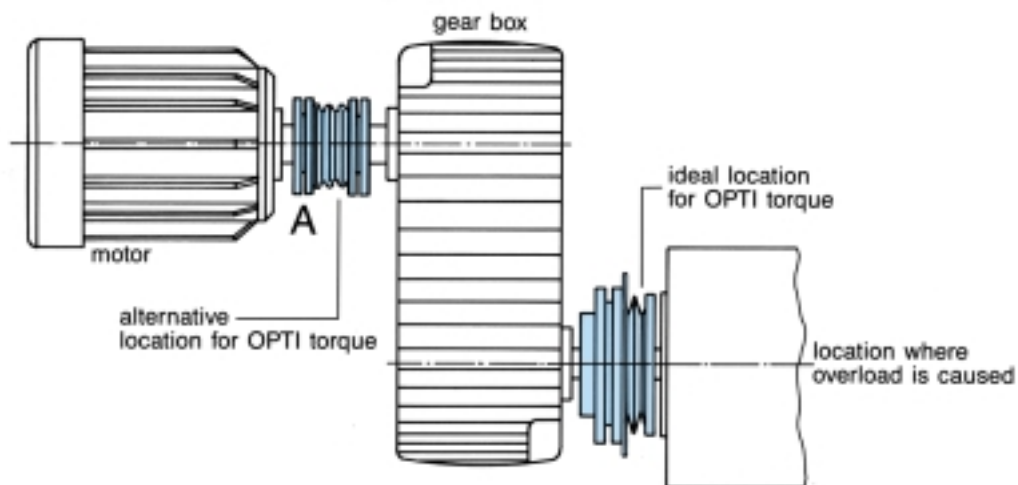
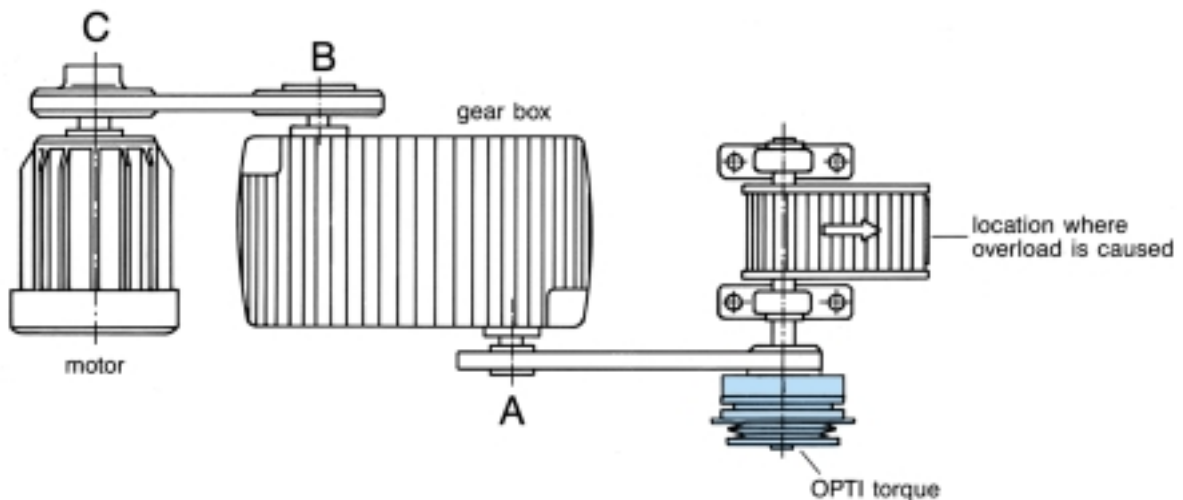

# OPTI torque

## Overload protection for virtually every application

Narrow drive elements such as this “A-plate” sprocket are easily mounted on the standard hub of the OPTI torque, making both a compact and economic package.

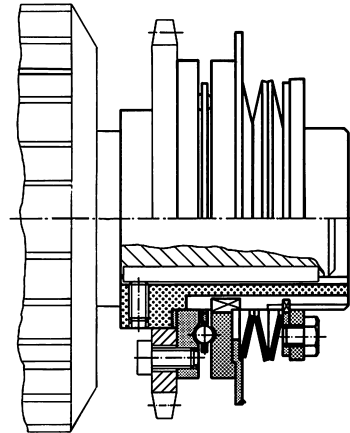

Combined with a flexible coupling, the OPTI torque connects drive and driven shafts, accomodating angular, axial and radial shaft misalignments, while also providing overload protection.

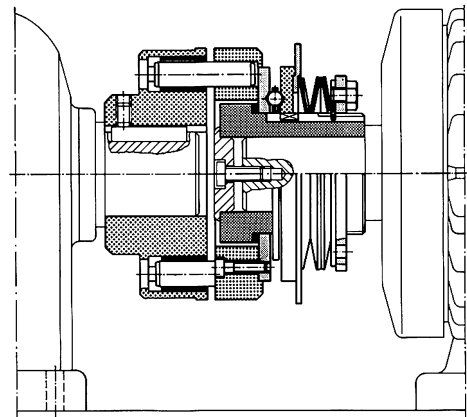

The extended hub and integral bushing of the OPTI torque makes it ideally suited for wider drive elements, such as this pulley. With the OPTI torque installed with the pulley inward, overhung load on the drive shaft is minimized, and easy access is provided for torque adjustments.

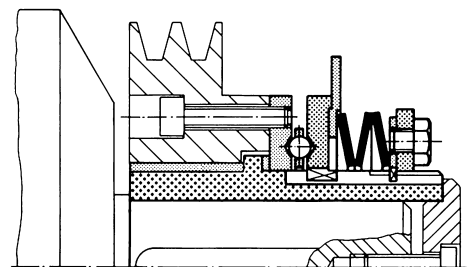

Designs for small drive elements.  
For use with sprockets, gears, pulleys, etc. with small pitch diameters.

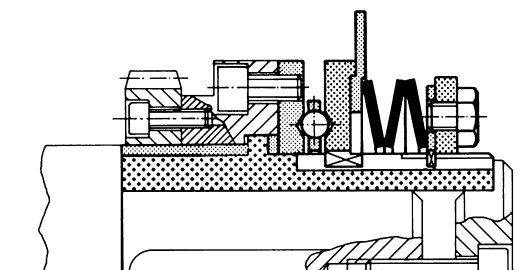

## Type 460.\_1\_.0

OPTI torque with standard hub

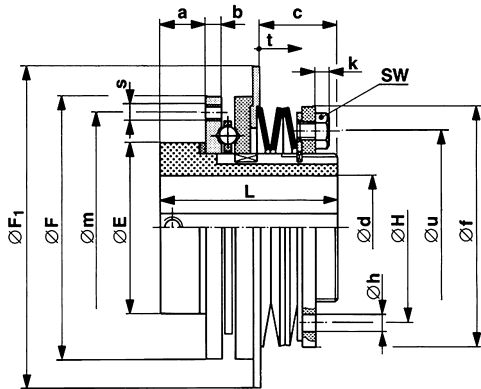

## Type 460.\_1\_.1

OPTI torque with extended hub

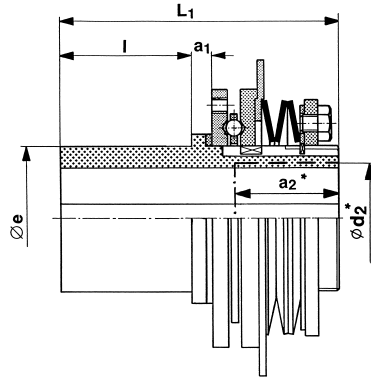

\*Counterbore a<sub>2</sub>/Ød<sub>2</sub> only with size 4

All other dimensions same as type 460.\_.0.

Please notice that all threads for set screws as shown above are provided only when ordered finish bored.

## Technical data and Dimensions

size	dim.	torque ranges							max. speed rpm
		multiple position clutch				single position clutch			
		type 46_.410._	type 46_.510._	type 46_.610._	type 46_.710._	type 46_.415._	type 46_.515._	type 46_.615._	
0	lbf x in Nm	26 – 53 3 – 6	53 – 106 6 – 12	106 – 221 12 – 25	221 – 354 25 – 40	53 – 106 6 – 12	106 – 221 12 – 25	221 – 354 25 – 40	500
1	lbf x in Nm	53 – 106 6 – 12	106 – 221 12 – 25	221 – 442 25 – 50	442 – 708 50 – 80	106 – 221 12 – 25	221 – 442 25 – 50	442 – 708 50 – 80	500
2	lbf x in Nm	142 – 265 16 – 30	265 – 531 30 – 60	531 – 1062 60 – 120	1062 – 1770 120 – 200	265 – 531 30 – 60	531 – 1062 60 – 120	1062 – 1770 120 – 200	500
3	lbf x in Nm	265 – 531 30 – 60	531 – 1062 60 – 120	1062 – 1770 120 – 200	1770 – 2655 200 – 300	531 – 1062 60 – 120	1062 – 1770 120 – 200	1770 – 2655 200 – 300	500
4	lbf x in Nm	354 – 796 40 – 90	796 – 1770 90 – 200	1770 – 3363 200 – 380	3363 – 5753 380 – 650	442 – 1328 50 – 150	1328 – 3098 150 – 350	3098 – 5753 380 – 650	500

size	dim.	stroke of output flange and limit switch plate t		a	a <sub>1</sub>	a <sub>2</sub>	b	type 46_._.10._ c	type 46_._.15._ c	d <sub>min</sub>	d <sub>max</sub>	d <sub>1 min</sub>	d <sub>1 max</sub>	d <sub>2</sub>
		multiple position clutch	single position clutch											
0	in mm	0.047 1,2	0.047 1,2	0.452 11,5	0.157 4	– –	0.197 5	0.854 21,7	0.834 21,2	0.375 9	0.8125 20	0.437 11	1.187 30	– –
1	in mm	0.079 2,0	0.059 1,5	0.649 16,5	0.177 4,5	– –	0.236 6	0.846 21,5	0.838 21,3	0.4375 12	1 25	0.5 12	1.625 42	– –
2	in mm	0.090 2,3	0.075 1,9	0.649 16,5	0.216 5,5	– –	0.236 6	1.075 27,3	1.083 27,5	0.5625 15	1.375 35	0.625 15	1.625 42	– –
3	in mm	0.102 2,6	0.087 2,2	0.866 22	0.275 7	– –	0.275 7	1.330 33,8	1.327 33,7	0.75 20	1.75 45	0.75 20	2.312 60	– –
4	in mm	0.102 2,6	0.087 2,2	0.866 22	0.551 14	2.362 60	0.314 8	1.575 40	1.650 41,9	1 25	2.165 55	1 25	2.312 60	2.204 56

# OPTI torque multiple /single position clutch

Type 460.\_1\_.2

OPTI torque with integral bushing

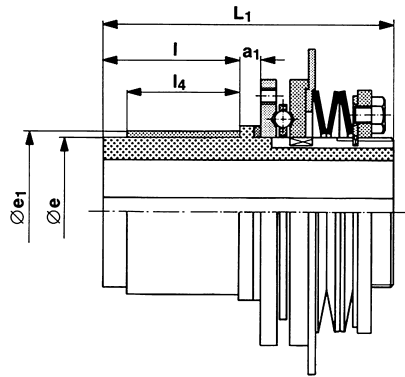

Type 462.\_1\_.0

OPTI torque combined with flexible coupling

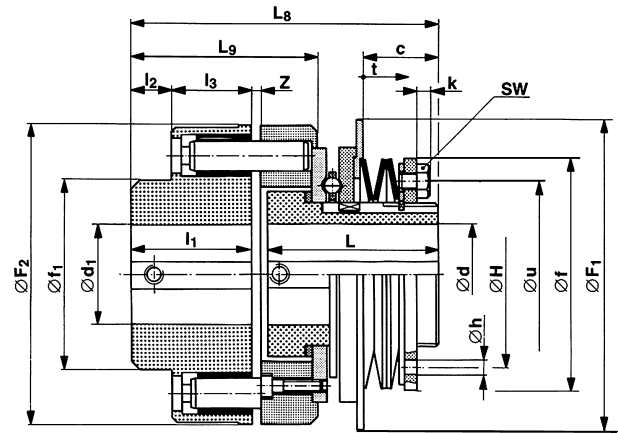

All other dimensions same as type 460.\_1\_.0.

Please notice that as shown above all threads for set screws are provided only when ordered finish bored.

## Technical Data and Dimensions

size	dim.	E <sub>h8</sub> <sup>1)</sup>	e <sub>h7</sub>	e <sub>1</sub> <sup>1)</sup>	F <sub>h8</sub>	F <sub>1</sub>	F <sub>2</sub>	f	f <sub>1</sub>	H	h	k
0	in mm	1.3385 34	1.1811 30	1.338 34	2.1653 55	3.150 80	3.150 80	1.653 42	1.968 50	1.457 37	0.118 3	0.019 <sup>2)</sup> 0,5 <sup>2)</sup>
1	in mm	1.7322 44	1.3779 35	1.535 39	2.7559 70	3.937 100	4.133 105	2.421 61,5	2.559 65	1.968 50	0.197 5	0.051 <sup>2)</sup> 1,3 <sup>2)</sup>
2	in mm	2.4409 62	1.9685 50	2.165 55	3.5433 90	4.724 120	4.133 105	3.169 80,5	2.559 65	2.637 67	0.236 6	0.118 3
3	in mm	2.9527 75	2.5590 65	2.755 70	4.5275 115	5.511 140	5.314 135	4.153 105,5	3.346 85	3.307 84	0.236 6	0.216 5,5
4	in mm	3.7401 95	2.9527 75	3.149 80	5.3149 135	6.692 170	6.299 160	5.137 130,5	3.543 90	4.094 104	0.275 7	0.216 5,5

size	dim.	L	L <sub>1</sub>	L <sub>8</sub>	L <sub>9</sub>	l	l <sub>1</sub>	l <sub>2</sub>	l <sub>3</sub>	l <sub>4</sub>	m	s	u	SW	Z
0	in mm	1.968 50	3.287 83,5	3.445 87,5	2.007 51	1.614 41	1.181 30	0.275 7	0.905 23	1.181 30	1.811 46	6x10-24 6xM5	1.456 37	0.078 <sup>2)</sup> 2 <sup>2)</sup>	0.157 4
1	in mm	2.244 57	3.700 94	4.074 103,5	2.559 65	1.929 49	1.653 42	0.393 10	1.259 32	1.574 40	2.322 59	6x10-24 6xM5	1.968 50	0.118 <sup>2)</sup> 3 <sup>2)</sup>	0.157 4
2	in mm	2.559 65	4.251 108	4.389 111,5	2.559 65	2.125 54	1.653 42	0.393 10	1.259 32	1.574 40	3.070 78	6x1/4-20 6xM6	2.637 67	0.393 10	0.157 4
3	in mm	3.188 81	4.999 127	5.551 141	3.307 84	2.401 61	2.165 55	0.748 19	1.417 36	1.968 50	3.937 100	6x1/4-20 6xM6	3.307 84	0.511 13	0.157 4
4	in mm	3.661 93	6.299 160	6.338 161	3.622 92	2.952 75	2.165 55	0.669 17	1.496 38	2.362 60	4.645 118	6x5/16-18 6xM8	3.819 97	0.511 13	0.236 6

## Order example:

To be included when ordering, please state:	size	Type	bore Ø d <sup>H7</sup>	bore Ø d <sub>1</sub> <sup>H7</sup>	<b>Examples:</b> 2/460.640.0/1 1/2 in 1/462.515.0/20mm/15 mm For limit switch details please refer to page 11.
<b>Order No:</b>		<b>46</b> _ . _ . _ . _			

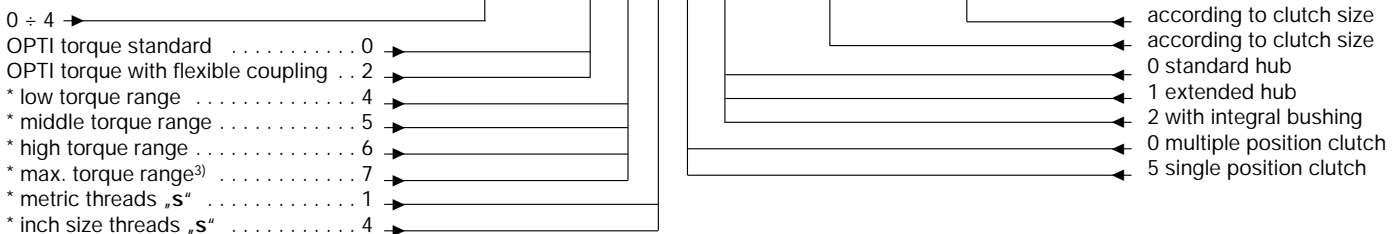

\* See technical data, torque ranges

1) please see page 8 for machining of drive elements

2) hexagon socket bolt DIN 7991

3) not with single position clutch

In accordance with our established policy to constantly improve our products, the specifications contained herein are subject to change without notice.





# OPTI torque

## Disc spring layer configuration

Only the correct disc spring configuration guarantees that the torques mentioned in the catalogue can be achieved and that the torque can be adjusted without problems.

The disc spring configuration is different and depends on the size and type of clutch.

<b>Size 0:</b>		<b>Size 1-4:</b>	
Type 46_415_	1x helical layer	Type 46_41_	3x single layer
Type 46_51_	5x single layer	Type 46_51_	3x single layer
Type 46_61_	5x double layer	Type 46_61_	3x single layer
Type 46_710_	3x triple layer	Type 46_710_	3x double layer

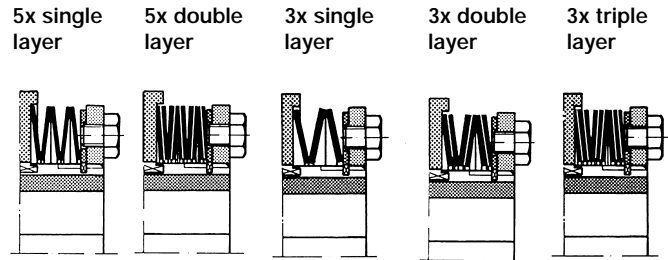

## Torque adjustment

The disengaging torque is set by turning the adjusting nut. Clockwise rotation of the adjusting nut (when viewed as shown) increases the torque setting, and counter-clockwise rotation decreases the torque setting.

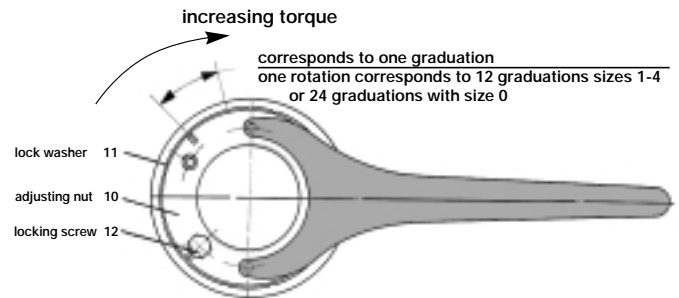

## Initial torque setting

Prior to initially setting the disengaging torque, check that the thread on the adjusting nut and hub, and contact surfaces of the adjusting nut and lockwasher have been greased. Then proceed as follows:

- \* Manually tighten the adjusting nut until it contacts the discs springs
- \* Continue turning until the notches in lock washer are in line.

- \* Using a face wrench, tighten the adjusting nut the required number of graduations corresponding to the desired torque setting, as shown in the setting diagrams.
- \* When the notches in the adjusting nut and lock washer are again in line, the locking screw can be installed.

## Setting example

A size 3, type 4\_610\_ OPTI torque is to be set at 1500 lbs-in.

From the setting diagram (included with every clutch) the required number of graduations is 15. Following the above instructions, the adjusting nut is tightened 15 graduations.

OPTI torque size	wrench Type
0	1
1	3
2	2
3	2
4	2

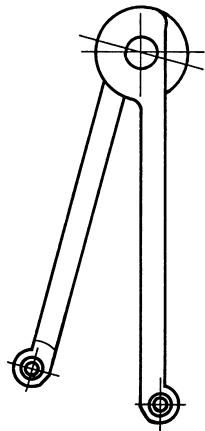
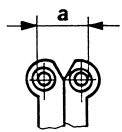

wrench 1 a = .368 [in]

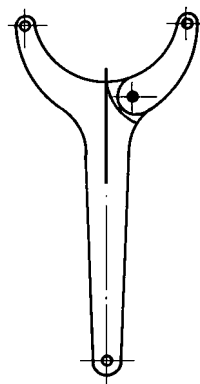

wrench 2

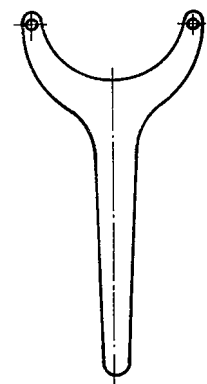

wrench 3

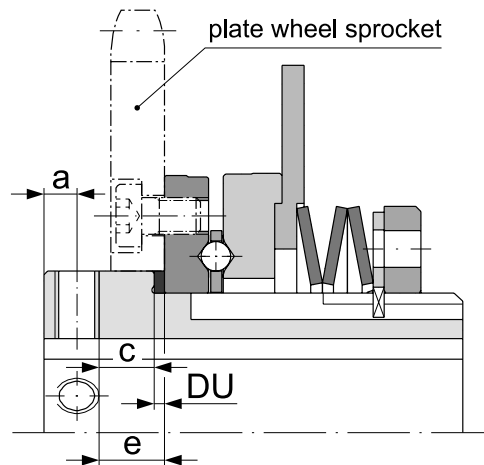

Recommended set screw sizes and position of plate wheel sprocket

size	set screw metric	dimension "a"		dimension "c"		dimension "e"		DU disc	
		mm	inch	mm	inch	mm	inch	mm	inch
0	M4	3	0.118	5	0.197	6,5	0.256	1,5	0.059
1	M6	4,5	0.177	7,5	0.295	9	0.354	1,5	0.059
2	M6	4,5	0.177	7,5	0.295	9	0.354	1,5	0.059
3	M8	6	0.236	10	0.394	12	0.472	2	0.079
4	M8	6	0.236	10	0.394	12	0.472	2	0.079

Recommended set screw sizes and position (ANSI)

size	set screw	dimension "a"		dimension "c"		dimension "e"		DU disc	
		mm	inch	mm	inch	mm	inch	mm	inch
0	10-32 UNF	3	0,118	4,6	0.181	6,1	0.240	1,5	0.059
1	1/4-20 UNC	4.5	0.177	7,3	0.287	8,8	0.346	1,5	0.059
2	5/16-18 UNC	4.5	0.177	6,5	0.256	8	0.315	1,5	0.059
3	5/16-18 UNC	6	0.236	10	0.394	12	0.472	2	0.079
4	3/8-16 UNC	6	0.236	9,2	0.362	11,2	0.441	2	0.079

Standard keyways used

DIN 6885 (mm)		ANSI (in.)	
bore	keyway	bore	keyway
17 – 22	6 x 2,8	5/8 – 7/8	3/16 x 3/32
23 – 30	8 x 3,3	15/16 – 1 – 1/4	1/4 x 1/8
31 – 38	10 x 3,3	1 – 5/16 – 1 – 3/8	5/16 x 5/32
39 – 44	12 x 3,3	1 – 7/16 – 1 – 3/4	3/8 x 3/16
45 – 50	14 x 3,8	1 – 13/16 – 2	1/2 x 1/4
51 – 55	16 x 4,3	2 – 1/16 – 2 1/8	1/2 x 1/4

Tolerance chart for finish bore

dim.	shaft diameter	bore H7
mm	10 – 18	+ 0.018 0
in	0.39 – 0.7	+ 0.0007 0
mm	20 – 30	+ 0.021 0
in	0.7 – 1.2	+ 0.0008 0
mm	30 – 50	+ 0.025 0
in	1.2 – 2	+ 0.001 0

# Limit switch Type 055.000.5 (mechanical operation)



## Application

Monitoring of mechanical movements and final positions. Control switch for electronic and mechanical sequences. Measuring of axial disengaging movements, for example in connection with EAS®-clutches.

## Function

The pre positioned contact is unloaded by actuating the control lever: Open contacts 11-14 (21-24), close 11-12 (21-22).

## Design

The micro switch fitted into an aluminium die cast housing is actuated by a control lever. Operation is only possible in one direction.

The limit switch is fastened with M4 cap screws via two screw-on brackets attached diagonally.



## Technical data

Contact type	1 change-over contact (special design: 2 change-over contacts)
Switching capacity	250 VAC / 15 A (with 2 contacts: 10A) 24 VDC / 6 A 60 VDC / 1,5 A 250 VDC / 0,2 A min. 12 VDC/10 mA
Contact material	AgCdO 90/10
Switching frequency	max. 200 switching operations/min
Ambient temperature	-10 °C up to +85 °C
Protection	IP 54
Weight	275 g
Switch travel setting	By the adjusting screw (SW 7) arranged laterally the zero shift is possible to right or left by max. 5 mm
Switch travel	Pre-travel min. 0,15 to 0,5 mm Over-travel: max. 10 mm, depending on the zero shift
Special types	On request different control lever lengths as well as a design with 2 change-over contacts are possible

## Dimensions (mm)

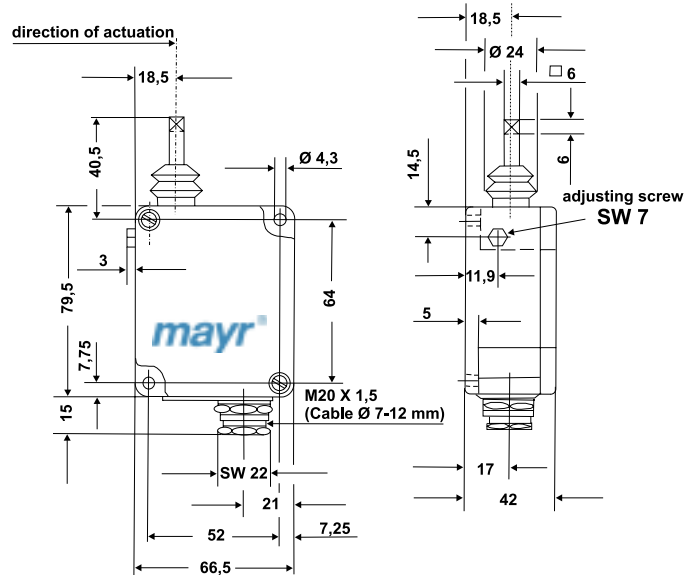

## Electrical connection

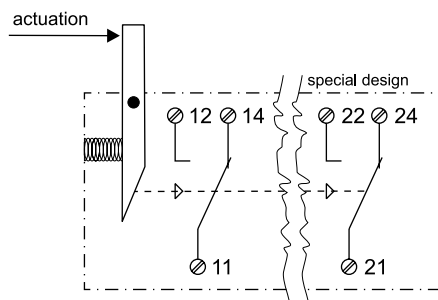

To be included when ordering, please state:	Type
Order number:	055.000.5

**Headquarters**

Chr. Mayr  
GmbH + Co. KG  
Eichenstraße 1  
87665 Mauerstetten  
Tel.: 49-83 41/8 04-241  
Fax: 49-83 41/804422  
info@mayr.de  
http://www.mayr.de

**Great Britain**

**Mayr Transmissions Ltd.**  
Valley Road,  
Business Park  
Keighley, BD21 4LZ  
West Yorkshire  
Tel.: 0 15 35/66 39 00  
Fax: 0 15 35/66 32 61  
sales@mayr.co.uk

**Italy**

**Mayr Italia S.r.l.**  
Viale Veneto, 3  
35020 Saonara (PD)  
Tel.: 0 49/8 79 10 20  
Fax: 0 49/8 79 10 22  
info@mayr-italia.it

**France**

**Mayr France S.A.**  
Z.A.L. du Minopole  
BP 16  
62160 Bully-Les-Mines  
Tel.: 03.21.72.91.91  
Fax: 03.21.29.71.77  
contact@mayr.fr

**Switzerland**

**Mayr Kupplungen AG**  
Tobelackerstrasse 11  
8212 Neuhausen  
am Rheinfall  
Tel.: 0 52/6 74 08 70  
Fax: 0 52/6 74 08 75  
info@mayr.ch

**USA**

**Mayr Corporation**  
4 North Street  
Waldwick  
NJ 07463  
Tel.: 2 01/4 45-72 10  
Fax: 2 01/4 45-80 19  
info@mayrcorp.com

**Singapore**

**Mayr Transmission (S)**  
Pte. Ltd. – Blk 133  
Jurong East Street 13  
Unit 03-291  
Singapore 600133 Asean  
Tel.: 0065/6560 1230  
Fax: 0065/6560 1000  
info@mayr.com.sg

**China**

**Mayr Shanghai**  
Room 608, No. 1277  
West Zhongshan Road,  
Conch Building,  
200051 Shanghai, China  
Tel.: 021/62953138  
Fax: 021/62953137  
sales@mayr.com.cn

**Korea**

Mayr Korea  
60-11, Woongnam-Dong  
ROK Changwon  
Rep. of Korea  
Tel.: 055/262-4024  
Fax: 055/262-4025  
info@mayrkorea.com

**Japan**

Sumitomo HI-PTC  
Sales Co., Ltd.  
3-5-8, Kandakaji-Cho,  
Chiyoda-Ku  
Tokyo J101-0045  
Tel.: 03/52563091  
Fax: 03/52563098  
Gotou.k@sumiju.co.jp



**Taiwan**

German Tech Auto Co. Ltd.  
No. 58, Wu Chuan Road  
Wu-Ku Industrial Park  
Taipei Hsien, Taiwan  
Tel.: 02/22990237  
Fax: 02/22990239  
steve@zfgta.com.tw

**India**

National Engineering  
Company (NENCO)  
J-225, M.I.D.C. Bhosari  
Pune 411 026  
Tel.: 0202/7 47 45 29  
Fax: 0202/7 47 02 29  
nenco@vsnl.com

**Australia**

Transmission Australia Pty. Ltd.  
22 Corporate Ave,  
3178 Rowville, Victoria  
Australien  
Tel.: 039/755 4444  
Fax: 039/755 4411  
info@transaus.com.au

**South Africa**

Torque Transfer  
Private Bag 9  
Elandsfontein 1406  
Tel.: 011/3458000  
Fax: 011/9740524  
torque@bearings.co.za

**Machine Tool**

**Applications in China**  
DTC. Co.Ltd.,  
Block 5th, No. 1699,  
East Zhulu Road,  
201700 Shanghai, China  
Tel.: 021/59883978  
Fax: 021/59883979  
dtcshanghai@online.sh.cn

Austria

Benelux States

Brazil

Canada

Czech Republic

Denmark

Finland

Greece

Hongkong

Hungary

Indonesia

Israel

Malaysia

New Zealand

Norway

Philippines

Poland

Romania

Russia

Slovakia

Slovenia

Spain

Sweden

Thailand

Turkey

Note:  
If a country is not  
shown, please refer  
to headquarters or  
our web site to be  
advised of the  
nearest responsible  
agent.